

DETAIL LEGEND:

- ① HUNTER PGP 6" POP-UP ROTOR
- ② SWING JOINT ASSEMBLY: TYPE PER PLAN OR SPECIFICATION
INSTALL AS FOLLOWS:
 - A. HAND TIGHTEN O-RING JOINTS, BACK-OFF ONE FULL TURN TO ALLOW FOR SWING ACTION.
 - B. INSTALL SWING JOINT LAY ARM AT 30°- 45° ANGLE TO THE LATERAL.
- ③ LATERAL TEE OR ELL CONNECTION PER LATERAL LINE FITTING SPECIFICATIONS.
- ④ LATERAL PIPE PER LATERAL LINE SPECIFICATIONS. SOIL DEPTH AS SPECIFIED.
- ⑤ FINISH GRADE

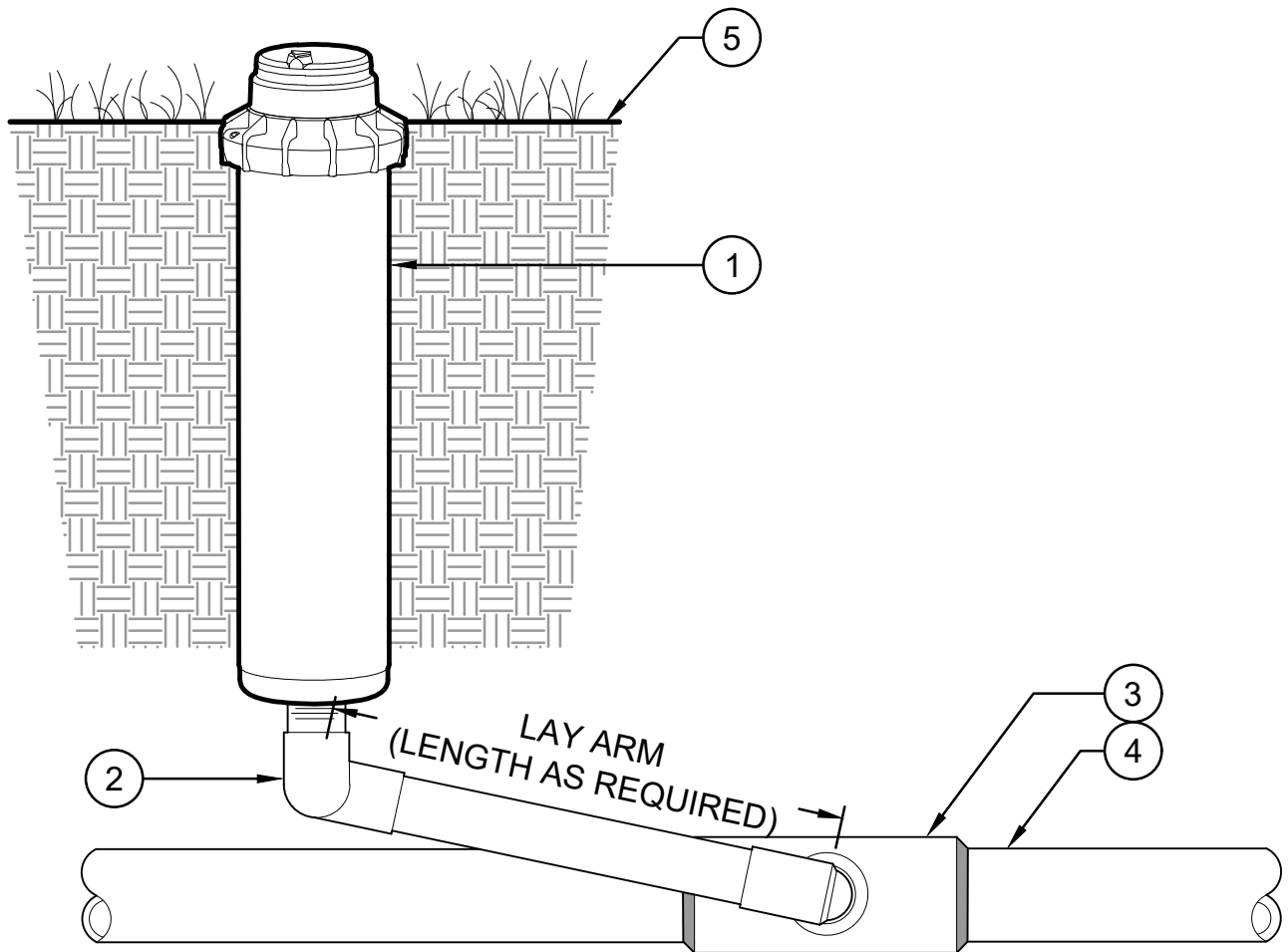

6" POP-UP ROTOR (PGP-06)

Hunter® R.PGP-06.02

NOT TO SCALE
REV: 2020-11-30