

WR-GUARD INSTALLATION INSTRUCTIONS

STAINLESS STEEL RECEIVER GUARD FOR WIRELESS
SOLAR SYNC® AND WIRELESS RAIN-CLIK®

Hunter®

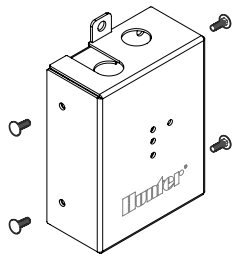

Solar Sync Receiver Installation

Assemble the following tools and materials:

- Safety glasses to protect yourself from metal shards
- Hardened steel center punch
- Variable speed drill
- 5/16" (8 mm) and 7/8" (22 mm) drill bits
- Lubricant for the drill site (such as lithium/moly grease and/or cutting oil)

Apply lubricant to the drill bit before drilling. Using a low speed with heavy pressure, drill completely through the pedestal wall. Reapply lubricant as needed to prevent the drill bit from overheating. Repeat this step to drill all required holes.

Remove all four enclosure screws using the PGP® adjustment tool or #8-32 hex Allen wrench.

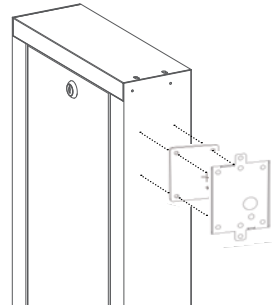

Pedestal Mounting

- 1 Place the provided template with the printed side facing out and upright against the available area on the pedestal where WR-GUARD will be installed.
- 2 Center-punch the pedestal where the holes for the bolts will be placed and drill with a 5/16" (8 mm) drill bit.
- 3 Center-punch the pedestal where the receiver wires exit the Solar Sync receiver and drill with a 7/8" (22 mm) drill bit.
- 4 Place the foam gasket and back plate of the guard against the pedestal and insert the provided bolts. Fasten with the included nuts.

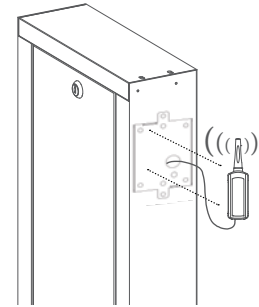

- 5 Fully insert the receiver wires through the back plate and foam gasket into the drilled pedestal hole.
- 6 Attach the Solar Sync receiver to the back plate and securely fasten with the plastic nut included with the sensor installation kit.

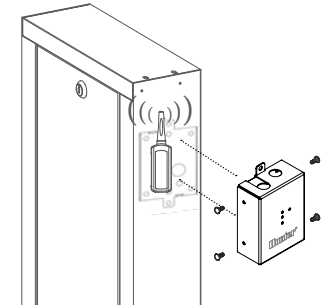

- 7 Attach the front plate of the guard and securely fasten with the provided screws.

Note: Always install WR-GUARD on a metal or stainless steel pedestal. Improper installation to a controller enclosure or other object could result in water damage or a fire hazard and violates UL compliance.

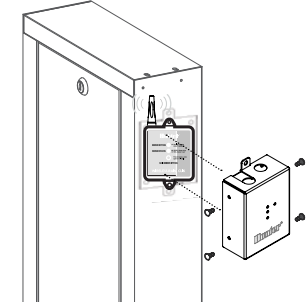
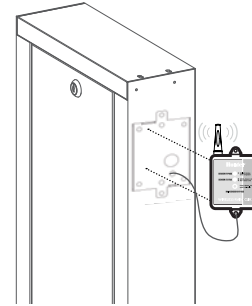
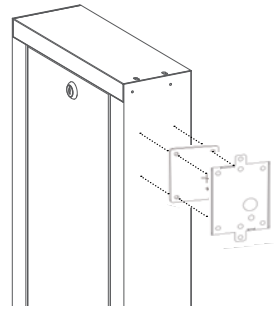
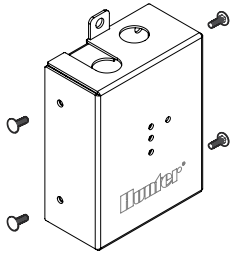

Rain-Clik Receiver Installation

Assemble the following tools and materials:

- Safety glasses to protect yourself from metal shards
- Hardened steel center punch
- Variable speed drill
- $\frac{5}{16}$ " (8 mm) and $\frac{1}{32}$ " (9 mm) drill bits
- Lubricant for the drill site (such as lithium/moly grease and/or cutting oil)

Apply lubricant to the drill bit before drilling. Using a low speed with heavy pressure, drill completely through the pedestal wall. Reapply lubricant as needed to prevent the drill bit from overheating. Repeat this step to drill all required holes.

Remove all four enclosure screws using the PGP adjustment tool or #8-32 hex Allen wrench.

Choose Pedestal or Flat Surface Mounting.

Pedestal Mounting

- 1 Place the provided template with the printed side facing out and upright against the available area on the pedestal where WR-GUARD will be installed.
- 2 Center-punch the pedestal where the holes shall be placed and drill with a $\frac{5}{16}$ " (8 mm) drill bit.
- 3 Center-punch the pedestal where the receiver wires exit the Rain-Clik receiver and drill with a $\frac{1}{32}$ " (9 mm) drill bit.
- 4 Place the foam gasket and back plate of the guard against the pedestal and insert the provided bolts. Fasten with the included nuts.

Move to Step 5

Flat Surface Mounting

- 1 Place the foam gasket and back plate of the guard against a flat surface near the irrigation controller.
- 2 Secure the back plate with two screws.

Move to Step 5

- 5 Fully insert the receiver cable through the back plate and foam gasket into the drilled pedestal hole or exit sensor cable with $\frac{1}{2}$ " (12 mm) electrical conduit.
- 6 Attach the Rain-Clik receiver to the back plate and securely fasten with the pre-installed screws.

- 7 Attach the front plate of the guard and securely fasten with the provided screws.

Note: Always install WR-GUARD on a metal or stainless steel pedestal. Improper installation to a controller enclosure or other object could result in water damage or a fire hazard and violates UL compliance.