

PLAN VIEW
(COVER NOT SHOWN FOR CLARITY)

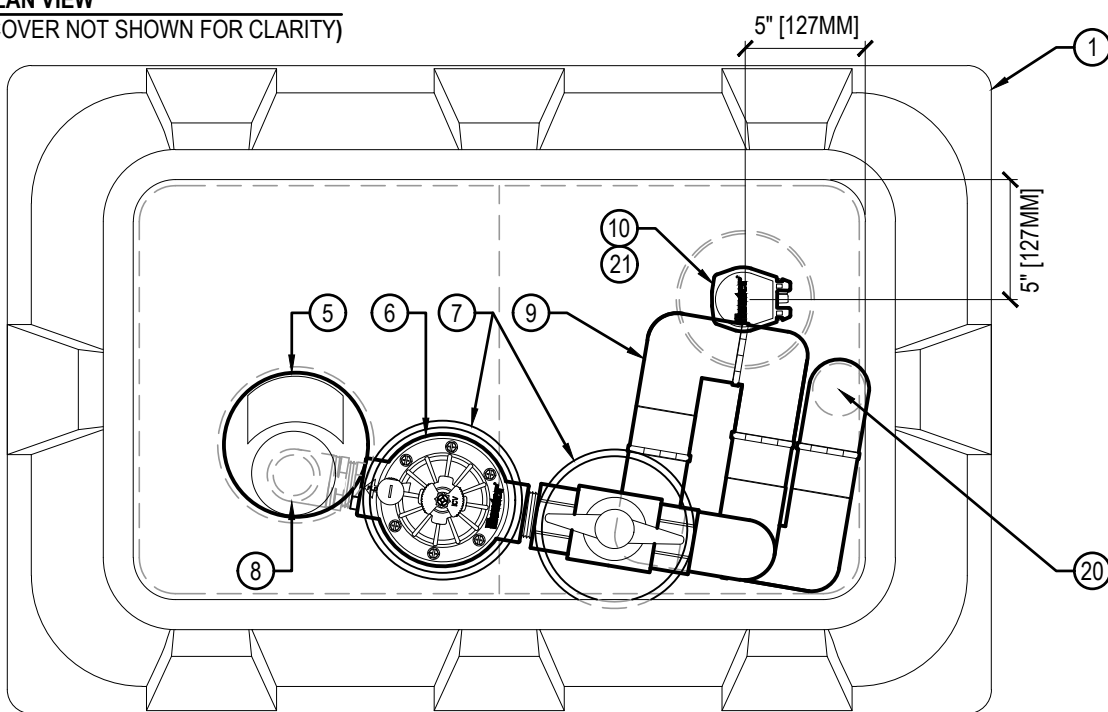

SECTION VIEW

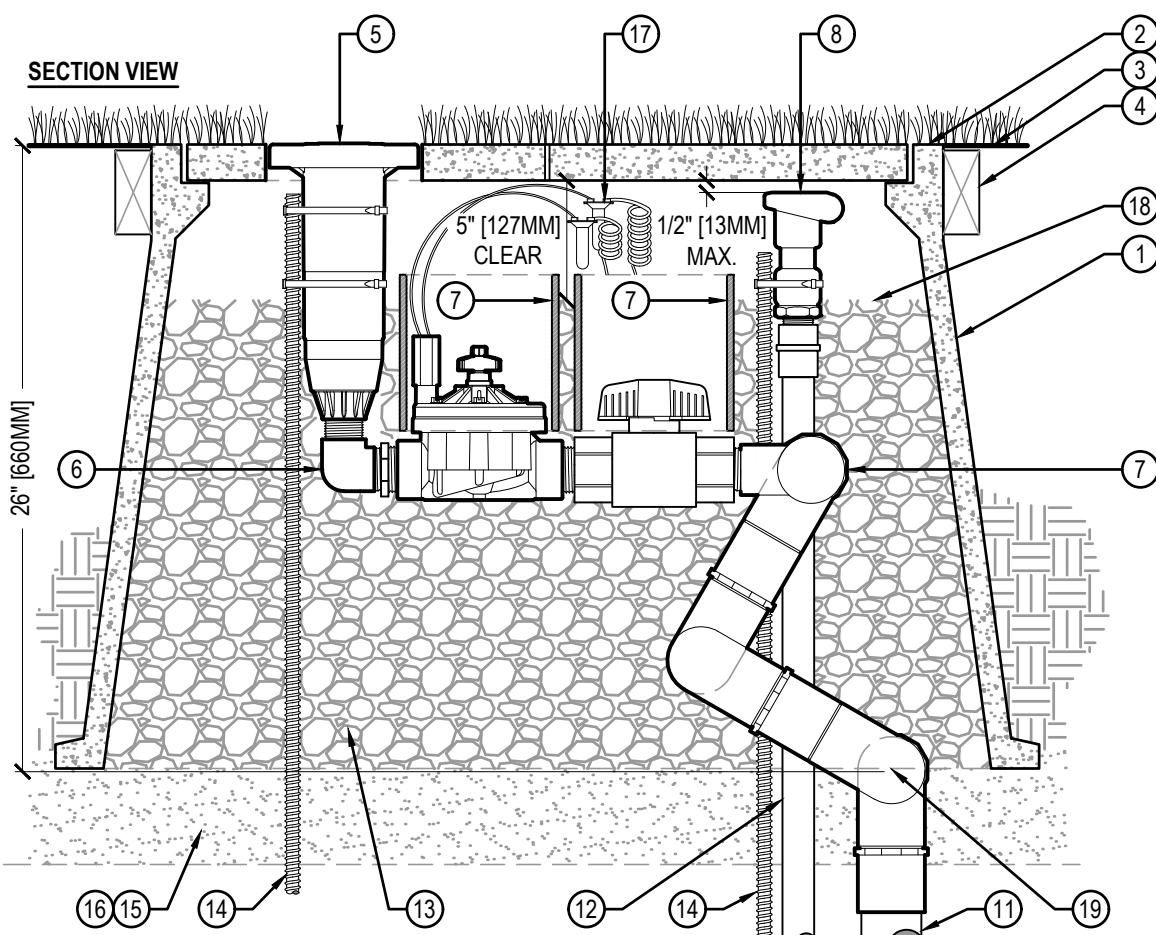

LEGEND

- ① HUNTER ST173026B* COMPOSITE BOX & 2-PIECE POLYMER-CONCRETE LID ASSEMBLY WITH CAST-IN OPENING TO SUPPORT ROTOR LATERAL THRUST PLUS CAST IN OPENING WITH CIRCULAR COVER FOR QUICK COUPLER ACCESS
- ② SYNTHETIC TURF GLUED TO COVERS (OR AS SPECIFIED)
- ③ FINISHED GRADE SET TO FIELD PERIMETER TACK/GLUE BOARD OR AS SPECIFIED
- ④ TACK/GLUE BOARD AS SPECIFIED (ALL SIDES)
- ⑤ HUNTER STG-900 WITH RUBBER COVER KIT 473900 INSTALLED
- ⑥ HUNTER STVBVFK KIT - INCLUDES HUNTER ICV-151G, 1-1/2" BALL VALVE (235PSI RATED), AND ACME PIVOT CONNECTION FITTINGS
- ⑦ CONTROL VALVE SLEEVE, 6" DIAMETER X 11" TALL WITH 2 NOTCHED SECTIONS FOR PIPING (OR AS SPECIFIED).
- ⑧ HUNTER 239800 ROTOR ADAPTER FITTING WITH 2 ACME PIVOT POINTS
- ⑨ HUNTER ST2008VA PREFABRICATED 2" SCH 80 PVC SWING JOINT WITH 6 ACME PIVOT POINTS TO PROVIDE MULTI-AXIS ARTICULATION AND ALIGNMENT OF ROTOR
- ⑩ HUNTER HQ5RC QUICK COUPLING VALVE
- ⑪ SUPPLY PIPING AND FITTINGS - 2" MINIMUM (OR AS SPECIFIED) FROM CONTROL VALVE TO ST2008VA SWING JOINT
- ⑫ SCH 80 PVC RISER SUPPLY PIPING AND FITTINGS - 1" MINIMUM
- ⑬ 3/4" MINUS WASHED GRAVEL
- ⑭ 5/8" X 30" REBAR STAKE AND STAINLESS STEEL PIPE CLAMPS
- ⑮ COMPACTED FIELD BASE MATERIAL AS SPECIFIED
- ⑯ PROVIDE DRAINAGE VIA FIELD DRAINAGE SYSTEM
- ⑰ WATERPROOF CONNECTIONS AS SPECIFIED
- ⑱ GRAVEL LEVEL 5" BELOW UNDERSIDE OF ENCLOSURE COVER (TO BOTTOM OF ROTOR'S COMPARTMENT)
- ⑲ ELEVATION OF SWING JOINT INLET - SET SECOND PIVOT POINT ON SWING JOINT WITH BOTTOM OF ENCLOSURE PER SIDE VIEW DETAIL DRAWING (26" BELOW ENCLOSURE TOP)
- ⑳ LOCATION OF SWING JOINT INLET - SET INLET AT CENTERLINE EDGE OF ENCLOSURE COVER PER PLAN VIEW. INLET CAN BE SET DIRECTLY BELOW ENCLOSURE RIM AT CENTERLINE. INLET MUST NOT BE SET CLOSER TO ROTOR THAN SHOWN.
- ㉑ LOCATION OF QUICK COUPLER INLET - MEASURE INLET PIPING LOCATION AT TOP RIGHT HAND CORNER OF ENCLOSURE - 5" FROM TOP EDGE AND 5" FROM SIDE EDGE.

*ENCLOSURE DIMENSIONS
 2 - PIECE COVER - 17" X 30"
 EXPOSED RIM - 20" X 33"
 OVERALL HEIGHT - 26"
 BASE PAD - 27" X 41"



SYNTHETIC TURF KIT (STK-2) WITH VALVE ADJACENT HEAD IN SYNTHETIC TURF

Hunter® STK.2.01

NO SCALE